

Description

Description

SL-DAA Series Smoke Duct Detector is the latest analog addressable innovation for early detection of smoke and products of combustion present in air moving through HVAC ducts in Commercial, Industrial, and Residential applications. The unit is designed to prevent the recirculation or spread of smoke by air handling systems, fans, and blowers. Complete systems may be shut down via the Harding network fire control panel in the event of smoke detection.

DL-DAA duct detectors connect to the SLC loop monitored and controlled by the Harding Analog Loop Module (ALM3-IP). The SL-DAA is addressed through the use of the patented XPERT™ programming card. The ALM monitors the SLC for faults and troubles and reports the SL-DAA status to the Harding fire control unit. When an alarm condition is reported to the system by the SL-DAA, pre-programmed output events energize Addressable Relay Modules (IOM2011) associated with the specific SL-DAA to take control of required building functions.

The SL-DAA is designed and built to meet all local code requirements, as well as the NFPA and ICC standards regarding HVAC supply and return duct smoke detectors. Output terminals are provided for a remote alarm indicator accessory.

The SL-DAA includes many features that represent true innovations from current generation duct smoke detectors.

The SL-DAA is shipped complete with a 7" exhaust tube, sampling tube end cap, a mounting template and mounting hardware.

Also offered are a number of accessory products including the MSR-50 and MSR-100 remote indicator/controls, a weatherproof enclosure and TG-2000 test gas.

- Models: Photo DXP-AD2-P (Model SL-DAA-P)
Ion DXP-AD2-I (Model SL-DAA-N)
- Sampling Tubes: STN:-1.0 12" or less
STN:-2.5 6" to 2.5'
STN:-5.0 2.5' to 5"
STN:-10.0 5.0' to 10'
- Air Velocity: 100-4000'/min.
- Humidity :10-95% RH Non-Condensing/Non-Freezing
- Wiring: Solid or Stranded #12 to #22 AWG terminals
- Dimensions: 13.5 L x 4.5 W x 2.25 H
- Max. Net Weight: 2 lbs.



Features

- Listed for velocities between 100-4000 ft./min
- Listed for high- temperature applications
- Patent pending "No-Tools Required" front or rear loading and removing sampling/exhaust tubes
- Patent pending "Test Port Valve" allows for aerosol smoke testing without cover removal
- Clear cover fitted with four captive "No-Tools Required" thumbscrews
- Instantaneous cover removal trouble indication
- Vertical terminal block for easier wiring
- External mounting tabs do not require cover removal to install
- Duct wall gaskets on back of enclosure are pre-installed
- Large terminal connection screws
- Compatible with the WP-2000 weatherproof enclosure

Listing

UL File: S2829
CSFM: 3240-1004:115
MEA Accepted: 73-92-E Vol. 35

• Document # DS-SLDAA-1.0 • Copyright © 2020 Harding Instruments Co. Ltd. • All Specifications are subject to change without notice • Printed in Canada



9564 Yellowhead Trail NW Tel 780.462.7100
Edmonton, Alberta, T5G 0W4 Fax 780.450.8396
sales@harding-tech.com www.harding-tech.com



Represented by:



Two-Wire Addressable Duct Detectors/Relay SL-DAA-P, N Detector

Engineer Specification

The contractor shall furnish and install, where indicated on the plans, ionization or photoelectric type duct detectors for the control of air handling units by the Fire Alarm control. The addressable analog duct detector will contain the patented XPERT programming card for ease of addressing. The addressable analog doctor shall also be capable of handling air velocities of 100 to 4000 feet per second, the detector head shall contain no additional screens or filters, a method of smoke testing the detector without removing the duct detector cover must be provided, cover and sampling tube or installation shall not require the use of tubes and sampling tubes must be capable of installation or removal from the front and rear of the detector for inspection and testing. The addressable analog duct detector shall be UL/ULC listed and UL/ULC listed as compatible with Harding network fire controls. The analog addressable duct detector shall be the Harding model SL-DAA-P (photo) and SL-DAA-N (ion).

Wiring Detail

Terminal Connections

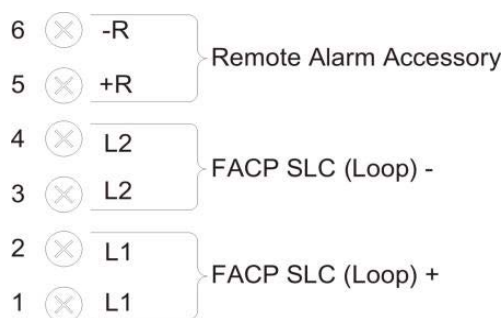

Remote Accessory Wiring

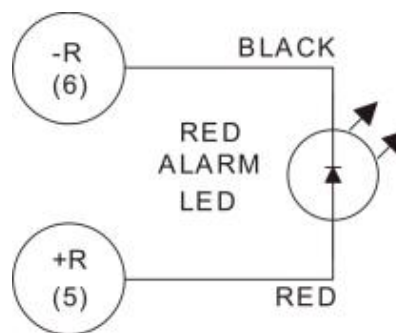

Ordering Information

Model	Data Sheet	Description
SL-DAA-P	DS-SLDAA-1.0	Addressable 2 Wire Photoelectric Duct Detector
SL-DAA-N	DS-SLDAA-1.0	Addressable 2 Wire Ionization Duct Detector

Related Modules

SL-DA4R-P	DS-SLD4R-1.0	Addressable 4 Wire Photoelectric Duct Detector
SL-DA\$R-N	DS-SLD4R-1.0	Addressable 4 Wire Ionization Duct Detector
MSR-50		MSR 50 Series Remote Accessories
MSR-100		MSR 100 Series Remote Accessories
WP2000		Weatherproof Enclosure
TG2000		Test Gas

Related Data Sheets

Series 21 Detectors: PHOTO (DET2104), DS2104; ION (DET2102), DS2102; HEAT (DET2101), DS2101; MULTI (DET2105), DS2105;

Series 22 Detectors: PHOTO (DET2204), DS2204; ION (DET2202), DS2202; HEAT (DET2201), DS2201; MULTI (DET2205), DS2205;

- Document # DS-SLDAA-1.0
- Copyright © 2020 Harding Instruments Co. Ltd.
- All Specifications are subject to change without notice
- Printed in Canada



9564 Yellowhead Trail NW
Edmonton, Alberta, T5G 0W4
sales@harding-tech.com

Tel 780.462.7100
Fax 780.450.8396
www.harding-tech.com



Represented by: